

PTZ CAMERAS AND UNITS, BRACKETS



UPTWBA

WALL MOUNT BRACKET

Made of die-cast aluminum

Epoxy polyester powder painting, RAL9002 colour

Wall bracket with internal cable channel

To combine with PTCC1 pole mount or WCWGC corner mount adaptors for the installation on several surfaces



UPTWBA

UPTWBTAB

PARAPET BRACKET

Made of die-cast aluminum

Epoxy polyester powder painting, RAL9002 colour

Internal cable management



UPTWBTAB

PTCC1

POLE MOUNT ADAPTOR

Made of aluminium

For pole diameters: from 80mm (3.1in) up to 150mm (5.9in)

Load rating: 50kg (110lb)



PTCC1

WCWGC

CORNER MOUNT ADAPTOR

Made of steel

Load rating: 50kg (110lb)



WCWGC

UCCMA

CEILING BRACKET FOR UPSIDE DOWN MOUNTING AND WORKING OF ULISSE COMPACT

Made of galvanized and painted steel

Safety cord in AISI316L stainless steel

Internal cable management



ULISSE COMPACT+UCCMA

TECHNICAL DATA

UPTWBA

MECHANICAL

Made of die-cast aluminum

Epoxy polyester powder painting, RAL9002 colour

Wall bracket with internal cable channel

To combine with PTCC1 pole mount or WCWGC corner mount adapters for the installation on several surfaces

Unit weight: 3.1kg (6.6lb)

PART NUMBER

UPTWBA Wall bracket with internal cable channel

PACKAGE

Model Number	Weight	Dimensions (WxHxL)	Master carton
UPTWBA	3.5kg (7.7lb)	19x16x60cm (7.5x6.3x23.6in)	-

UPTWBTAB

MECHANICAL

Made of die-cast aluminum

Epoxy polyester powder painting, RAL9002 colour

Internal cable management

Unit weight: 1.6kg (3.5lb)

PART NUMBER

UPTWBTAB Parapet bracket with internal cable channel

PACKAGE

Model Number	Weight	Dimensions (WxHxL)	Master carton
UPTWBTA	1.6kg (3.5lb)	19x19x19cm (7.5x7.5x7.5in)	12

PTCC1

MECHANICAL

Made of aluminium

For pole diameters: 80÷150mm (3÷5.9in)

Load rating: 50kg (110lb)

Unit weight: 2.6kg (5.7lb)

PART NUMBER

PTCC1 Pole mount adaptor

PACKAGE

Model Number	Weight	Dimensions (WxHxL)	Master carton
PTCC1	2.8kg (6.2lb)	14x25.5x20cm (5.5x10x7.9in)	8

WCWGC

MECHANICAL

Made of steel

Load rating: 50kg (110lb)

Unit weight: 2.2kg (4.8lb)

PART NUMBER

WCWGC Corner mount adaptor

PACKAGE

Model Number	Weight	Dimensions (WxHxL)	Master carton
WCWGC	2.6kg (5.7lb)	24x32x24.5cm (9.4x12.6x9.6in)	8

UCCMA

GENERAL

Internal cable management

MECHANICAL

Made of galvanized and painted steel

Safety cord in AISI316L stainless steel

Unit weight: 6.4kg (14lb)

CERTIFICATIONS

EAC certification

PART NUMBER

UCCMA Ceiling bracket for upside down mounting and working of ULISSE COMPACT

PACKAGE

Model Number	Weight	Dimensions (WxHxL)	Master carton
UCCMA	6.8kg (15lb)	35x37x12.5cm	-

TECHNICAL DRAWINGS

The dimensions of the drawings are in millimetres.

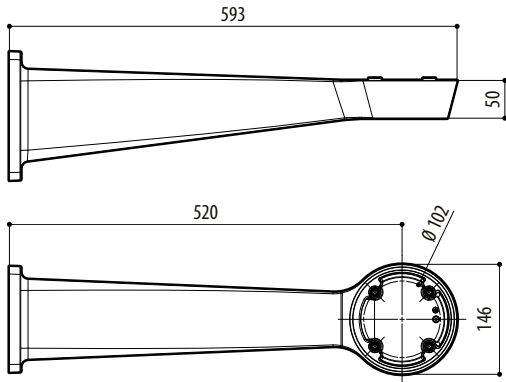

UPTWBA

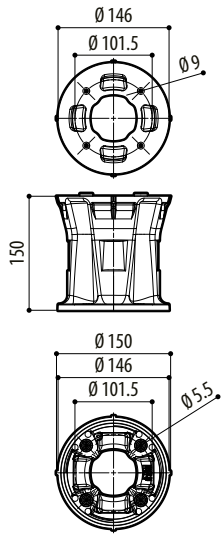
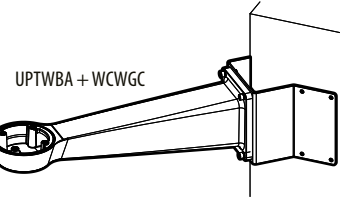
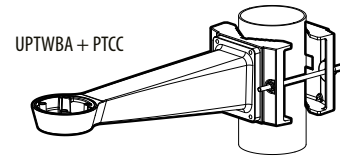
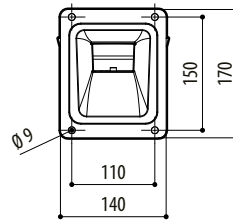

UPTWBTAB

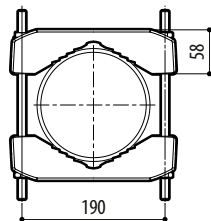
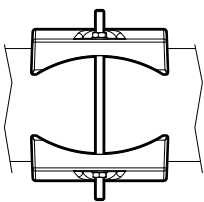
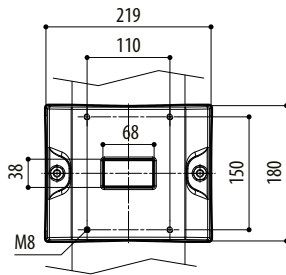

PTCC1

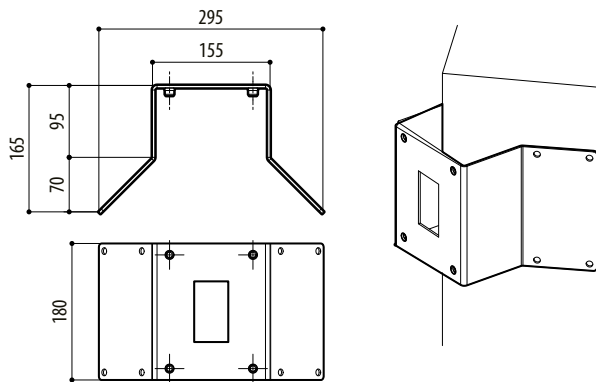

WCGC

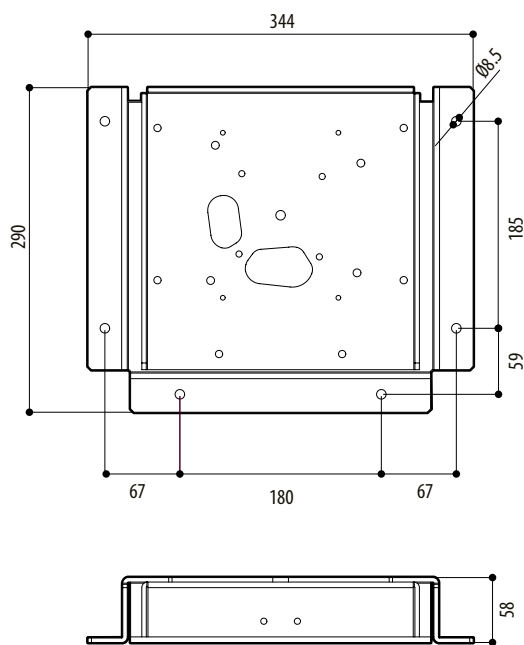

UCCMA