

Q6100-E Network Camera

Repainting Instructions

Q6100-E Network Camera

Impact on warranty

Impact on warranty

This product is approved for repaint by Axis, provided that you follow the instructions in this document and at axis.com/warranty-implication-when-repainting.

Risks with repainting

There are several risks when disassembling or assembling an Axis product. There is always a certain yield loss during assembly. Training of operators and the use of correct tools mediates some of the problems but they can never be fully avoided. Some of the risks include:

ESD Damage – Always handle the product in an ESD safe environment. Even if precautions are taken there is always a risk of ESD damage. The damage can remain undetected and cause problems during the lifetime of the equipment.

Dust contamination – Opening a camera may expose the lens and sensor to dust or paint. Dust will affect the optical performance. Lenses need to be disassembled in a dust-free environment, preferably a cleanroom.

Paint overspray – Masking the different components of the equipment is critical. Failure to mask sensitive areas can cause problems with assembling the equipment. Any areas that are not painted at factory or have a different surface treatment than the rest of the parts (threads, ground and electrical contact surfaces) must also be masked to ensure function.

Q6100-E Network Camera

Repaint the product

Repaint the product

Preparations

- If applicable, disassemble the device according to the instructions in this document.
- Clean all parts to be repainted thoroughly to remove grease, dust, or oil.
- To ensure reassembly and functionality of the product, mask any openings (for example for screws, LED indicators, or microphones) before you paint.

Pretreatment of parts

Depending on the part material and type of paint applied at factory, different pretreatment should be done for the new paint to adhere as well as possible. Clean the parts properly to remove oil, grease and dust.

For more information on the materials used in the product, see its datasheet at axis.com.

Powder coated parts – Use a primer. Alternatively, remove the original powder coating down to the base material, using fine sandpaper, and clean the parts before painting.

Anodised and chromated parts – Use a primer.

Uncoated stainless steel – No special pretreatment is needed, but make sure that the surface is clean before painting.

Plastic – Use a primer.

Q6100-E Network Camera

Repaint the product

Disassembly

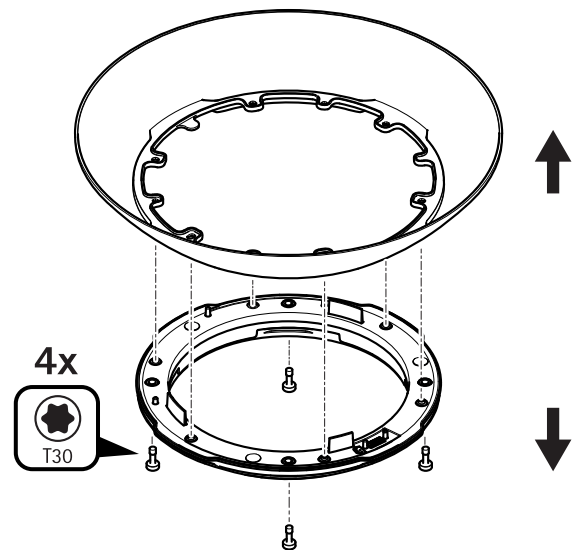
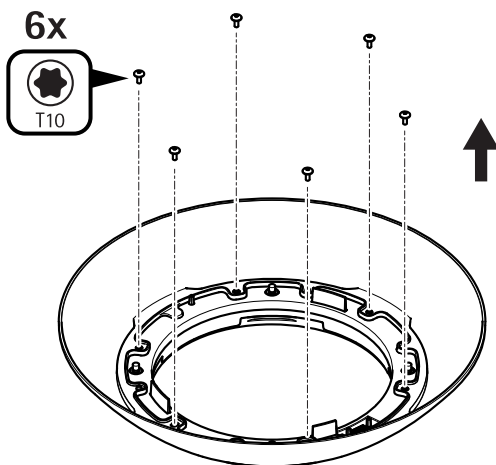
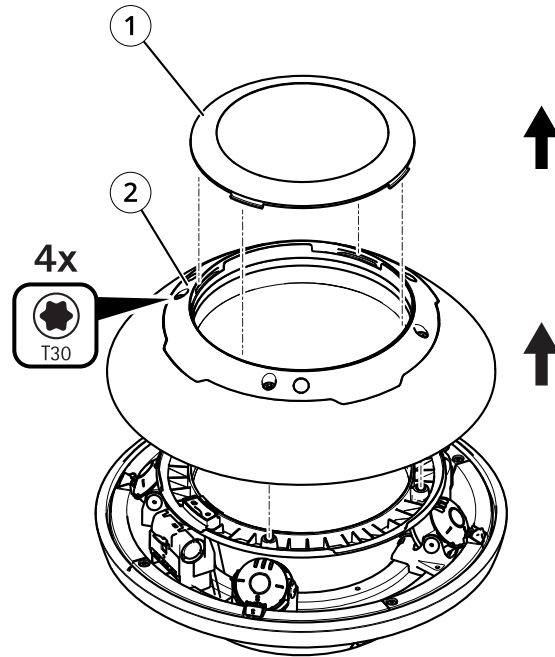

- 1 Cover ring
- 2 Dome ring

Q6100-E Network Camera

Repaint the product

1. Loosen the four screws from the dome ring and remove the cover ring.
2. Remove the four screws from the dome ring.
3. Slowly lift the inner edge of the dome ring. Be careful not to scratch or dent the dome.
4. Carefully lift the inner edge all way round to release the dome ring.
5. Remove the six screws from the ring and remove the ring from the dome.

Repainting

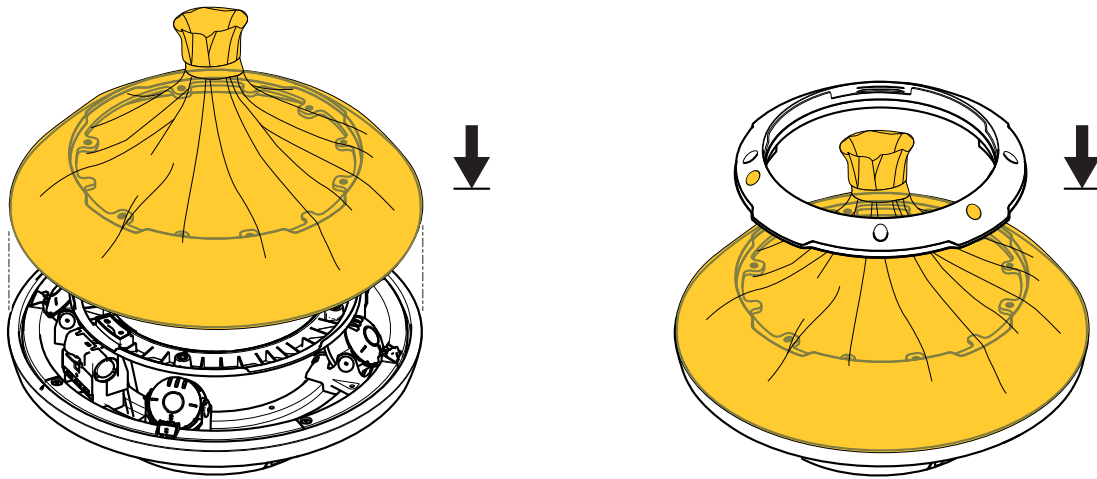

1. Mask the dome including the edge and the three microphone meshes.
2. Place the dome on the camera unit. Make sure the edge of the top cover can be painted.
3. Place the ring on top of the masked dome.

Q6100-E Network Camera

Repaint the product

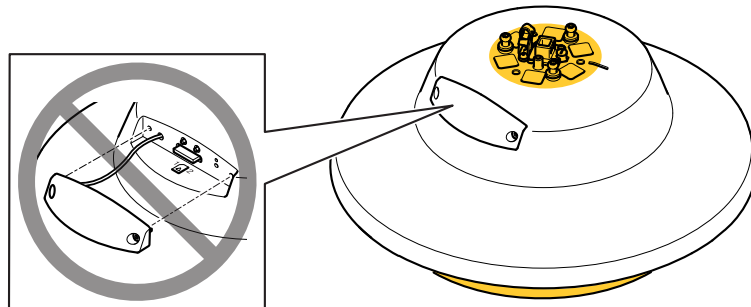

4. Mask the holder hook and all holes.
5. Make sure all necessary preparations of the camera unit and the cover ring have been made. See *Preparations on page 3*.

Note

The SD lid should not be removed during repainting, or else the SD lid gasket will be damaged.

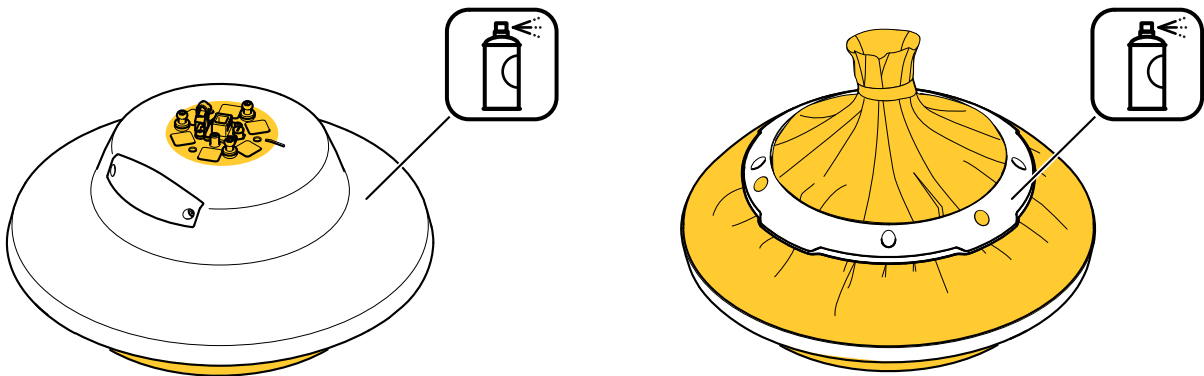

6. Apply a thin and even layer of spray paint according to the instructions of the paint manufacturer.
7. Let the paint dry.
8. To get a better coverage and clearer color, apply a second layer of spray paint.
9. When the paint is dry, remove the masking.

Q6100-E Network Camera

Repaint the product

Reassembly

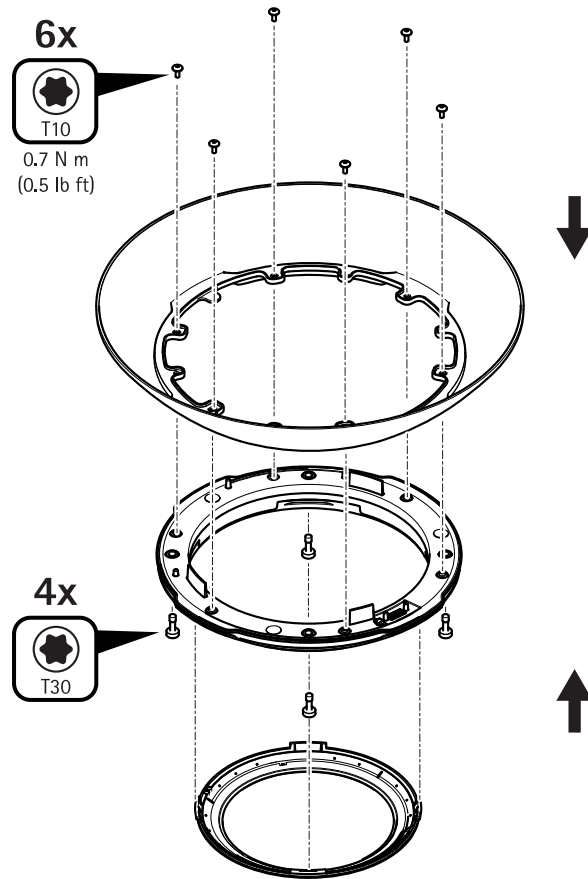

1. Reassemble the dome rings (6 screws, 0.7 N m).
2. Reassemble the cover ring (4 screws).

Q6100-E Network Camera

Repaint the product

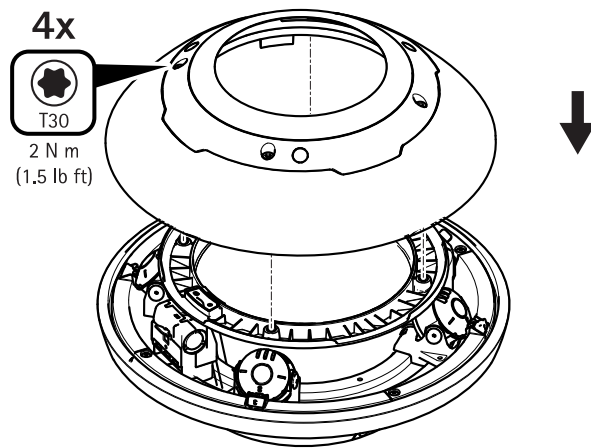

3. Attach the dome assembly to the camera (2 N m).

